



80L

GAS FIREPLACE
INSERT
LEFT HAND



TECHNICAL SPECIFICATIONS

CALMA gas fireplaces are modern devices that can work with G20 (high-methane natural gas), G27 (nitrogen-rich natural gas), G30 (propane-butane gas mixture) or G31 (propane gas) gas.

CALMA gas heaters have been adapted to work with POUJOLAT concentric air-flue gas systems, BI-GAS and DUO-GAS models in sizes 150/100 (CALMA 65, CALMA 80) and 200/130 (CALMA 120).

The heaters are adapted to work with a concentric system based on two coaxial pipes with a circular cross-section, from which the external one supplies air to the combustion chamber, and the internal one is responsible for the discharge of exhaust gases.

The air-flue gas system is made of acid-resistant steel and can be used in solutions where the flue gas temperature in the heater does not exceed 600 ° C.

The chimney systems used with CALMA gas appliances can be led out through the side wall of the building (type C11 system), through the roof (type C31 system), or use the existing chimney (type C91).

The device works only with gas for which it has been factory-adapted. The manufacturer allows the heater to be adapted to work with a gas other than the gas specified on the label. Changing the device settings is payable and may only be performed by the manufacturer's authorized service.

up to **8 years**
WARRANTY



Specially designed
and patented
TRIANGLE FLAME
burner



SAFETY
KIWA
LABORATORY CERTIFICATE



FIREPLACE
FOR RECUPERATION

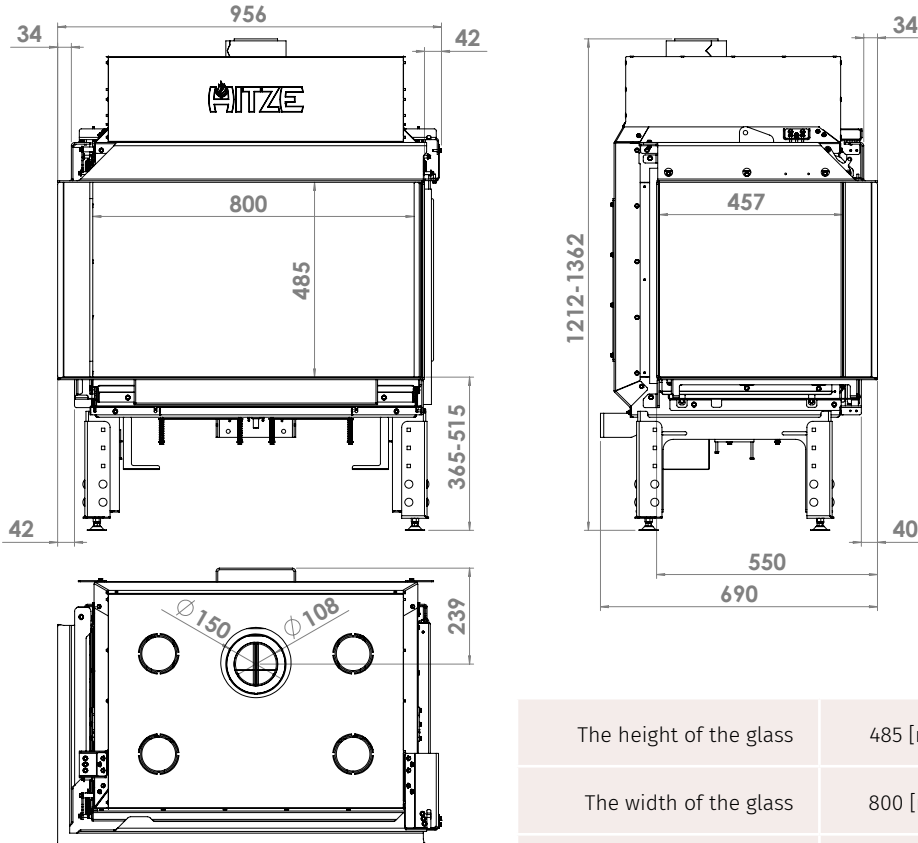

The height of the glass	485 [mm]
The width of the glass	800 [mm]
Side width of the glass	457 [mm]
Cartridge weight	143 [kg]



80L

GAS FIREPLACE
INSERT
LEFT HAND



DEVICE INSTALLATION

The internal gas installation is complete and only requires gas connection by the installer.

The seat of the heater should ensure the minimum number of bends of the co-operating concentric system and ensure the simplest possible routing of the gas supply pipe.

The device must be installed on a stable, non-flammable surface with the required load-bearing capacity. The device should be placed at least 1.2 meters from flammable materials and at least 50 mm from non-flammable walls.

CALMA line devices are adapted to be mounted on the wall (this requires the use of dedicated fasteners offered by the manufacturer).

The device has a two-stage height adjustment system - adjustable legs, in which additionally mounted feet with smooth height adjustment in the range of 0-25 mm.

		Reference gas			
Parameter	Unit	G20	G27	G30	G31
Pp	[mbar]	20	20	29/37/50	29/37/50
P reg Qn	[mbar]	6,4	9,9	7,9	9,5
P reg Qm	[mbar]	2,7	4,2	5,5	6,8
Qn/Qm	[kW]	10,8/7,2	10,3/6,7	10,7/8,8	10,2/8,5
V Pn/V Pm	[m ³ /h]	1,14/0,76	1,33/0,87	0,33/0,27	0,41/0,34
η	[%]	86,0	-	84,1	82,3
EEI	-	B	B	B	B
NO x class*	-	5		5	5

* emission level of nitrogen oxides according to EN 613

Pp - nominal connection pressure

P reg Qn - pressure downstream the regulator for nominal power

P reg Qm - pressure downstream the regulator for minimum power

Qn - nominal power according to Hi

Qm - minimum power according to Hi

V Pn - gas consumption stream for nominal power

V Pm - gas consumption stream for minimum power

η - device efficiency

EEI - Energy Efficiency Index

